

Fire Ventless Submittal Information

Spec Sheet	1.1
UL Ventless Label	2.1
UL Listing	3.1
UL KNLZ Explained	5.1
Notice of Authorization to Apply to UL Mark	5.1
Emissions by Product.....	6.1
Energy Usage Estimate.....	7.1
Surface Temperatures.....	8.1
Ventless Installation Recommendations	9.1
LA County Ventless Authorization.....	10.1



Project _____

Item No. _____

Quantity _____

THE Fire™



PERFORMANCE

The TurboChef Fire provides the artisan-hearth style pizza experience anywhere. Cooking at 842°F/450°C, the Fire can cook 14-inch fresh dough pizzas in as little as 90 seconds. The oven has a small footprint and is ventless, so it can be placed virtually anywhere without type I or type II ventilation.

VENTILATION

- UL (KNLZ) listed for ventless operation.[†]
- EPA 202 test (8 hr):
 - Product: Pepperoni Pizzas
 - Results: 0.48 mg/m³
 - Ventless Requirement: <5.00 mg/m³
- Internal catalytic filtration to limit smoke, grease, and odor emissions.

EXTERIOR CONSTRUCTION

- Powder coated (RAL-3020 - Traffic Red), corrosion-resistant steel outer wrap and door
- 430 stainless steel construction

INTERIOR CONSTRUCTION

- 430 stainless steel interior
- Double wall insulated cooling construction

STANDARD FEATURES

- Fits up to a 14-inch thin or thick dough pizza
- Integral catalytic converter for ventless operation
- Removable bottom access panel for easy cleaning
- Independent top and bottom electronic temperature control
- Top and bottom convection motors
- 6 preset timers
- Includes plug and cord (6 ft. nominal)
- Warranty – 1 year parts and labor

COMES WITH STANDARD ACCESSORIES

- 1 Stainless Steel Paddle
- 2 14-inch Aluminum Pizza Screens

COLOR OPTIONS (call for availability)

- Standard Color: Traffic Red (RAL-3020)
- Yellow Green (RAL-6018)
- Pure White (RAL-9010)
- Jet Black (RAL-9005)
- Blue (RAL-Custom TurboChef Blue)

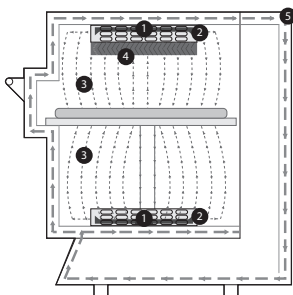

- Convection Fans
- Heaters
- Convection Airflow
- Catalytic Converter
- Insulated Cooling

This product conforms to the ventilation recommendations set forth by NFPA96 using EPA202 test method.

[†] Ventless certification is for all food items except for foods classified as "fatty raw proteins." Such foods include bone-in, skin-on chicken, raw hamburger meat, raw bacon, raw sausage, steaks, etc. If cooking these types of foods, consult local HVAC codes and authorities to ensure compliance with ventilation requirements.

Ultimate ventless allowance is dependent upon AHJ approval, as some jurisdictions may not recognize the UL certification or application. If you have questions regarding ventless certifications or local codes please email ventless.help@turbochef.com

TurboChef reserves the right to make substitutions of components or change specifications without prior notice.

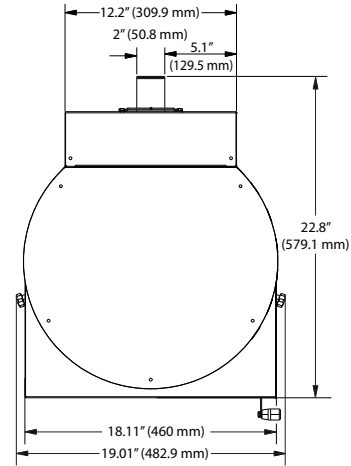
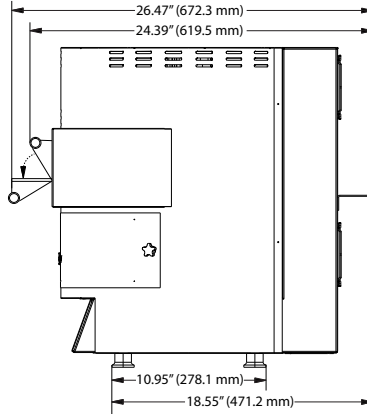
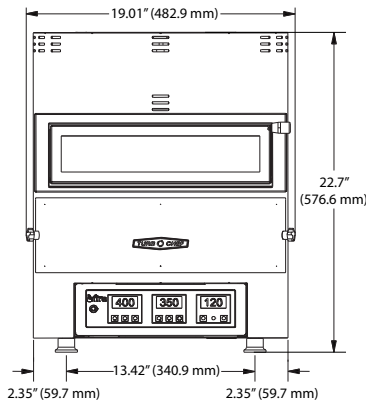

DIMENSIONS		
Height	21.70"	551 mm
with legs	22.70"	576.6 mm
Width	19.01"	482.9 mm
Depth (footprint)	18.55"	471.2 mm
with door closed	24.39"	619.5 mm
with door open	26.47"	672.3 mm
Weight	75 lb.	34 kg
Cook Chamber		
Width	14.75"	375 mm
Depth	14.75"	375 mm
Wall Clearance (Oven not intended for built-in installation)		
Top	2"	51 mm
Sides	2"	51 mm
Back	0"	0 mm

ELECTRICAL SPECIFICATIONS - SINGLE PHASE		
FRE-9600-1: Traffic Red (RAL 3020) - North America		
FRE-9600-2: Yellow Green (RAL 6018) - North America		
FRE-9600-4: Pure White (RAL 9010) - North America		
FRE-9600-5: Jet Black (RAL 9005) - North America		
FRE-9600-6: Blue (Custom) - North America		

Voltage	208 / 240 VAC	 NEMA 6-30P
Watts	3700 / 4800 W	
Frequency	50 / 60 Hz	
Breakers	30 Amp	
Input Current	17.5 - 20.5 Amp	

FRE-9600-7-UK: Traffic Red (RAL 3020) - Europe/Asia/South America		
FRE-9600-8-UK: Yellow Green (RAL 6018) - Europe/Asia/South America		
FRE-9600-10-UK: Pure White (RAL 9010) - Europe/Asia/South America		
FRE-9600-11-UK: Jet Black (RAL 9005) - Europe/Asia/South America		
FRE-9600-12-UK: Blue (Custom) - Europe/Asia/South America		

Voltage	230 VAC	 IEC 60309
Watts	4500 W	
Frequency	50 / 60 Hz	
Breakers	32 Amp	
Input Current	17.5 - 20.5 Amp	

FRE-9600-13-AK: Traffic Red (RAL 3020) - Australia		
FRE-9600-14-AK: Yellow Green (RAL 6018) - Australia		
FRE-9600-16-AK: Pure White (RAL 9010) - Australia		
FRE-9600-17-AK: Jet Black (RAL 9005) - Australia		
FRE-9600-18-AK: Blue (Custom) - Australia		

Voltage	230 VAC	 Clipsal 56PA320
Watts	4500 W	
Frequency	50 / 60 Hz	
Breakers	32 Amp	
Input Current	17.5 - 20.5 Amp	

ELECTRICAL SPECIFICATIONS - MULTI PHASE

FRE-9600-25-EW: Traffic Red (RAL 3020) - Europe/Asia/South America		
FRE-9600-26-EW: Yellow Green (RAL 6018) - Europe/Asia/South America		
FRE-9600-28-EW: Pure White (RAL 9010) - Europe/Asia/South America		
FRE-9600-29-EW: Jet Black (RAL 9005) - Europe/Asia/South America		
FRE-9600-30-EW: Blue (Custom) - Europe/Asia/South America		

Voltage	380 - 415 VAC	 IEC 309, 5-pin
Watts	4510 / 4940 W	
Frequency	50 / 60 Hz	
Breakers	20 Amp	
Input Current	11.5/1.4/9.2 Amp	

FRE-9600-19-AU: Traffic Red (RAL 3020) - Australia		
FRE-9600-20-AU: Yellow Green (RAL 6018) - Australia		
FRE-9600-22-AU: Pure White (RAL 9010) - Australia		
FRE-9600-23-AU: Jet Black (RAL 9005) - Australia		
FRE-9600-24-AU: Blue (Custom) - Australia		

Voltage	380 - 415 VAC	 Clipsal 5-pin
Watts	4510 / 4940 W	
Frequency	50 / 60 Hz	
Breakers	20 Amp	
Input Current	11.5/1.4/9.2 Amp	

SHORT FORM SPECIFICATIONS

Provide TurboChef Fire countertop oven. The Fire oven cooks artisan and traditional style pizzas up to 14 inches. The Fire oven allows an operator to independently control the top and bottom temperature in the cavity which ensures precise delivery of top and bottom heat. Additionally, it features 6 preset timers. The Fire oven uses TurboChef catalytic technology in order to eliminate smoke and grease during operation, allowing the oven to be UL®-certified for ventless operation. The exterior and interior are constructed with 430 stainless steel. The outer wrap and door are available in six powder-coated colors (red, green, black, white, or blue).

SHIPPING INFORMATION

All ovens are packaged in a triple-wall corrugated box banded to a wooden skid.
Box size (including skid): 34" (864 mm) x 30" (762 mm) x 34" (864 mm)
Item class: 110 NMFC #26710 HS code 8419.81
Approximate boxed weight: 100 lb. (45 kg)
Minimum entry clearance required for box: 34.5" (876 mm)

TurboChef Global Operations
 2801 Trade Center Drive / Carrollton, Texas 75007 USA
 US: 800.90TURBO (800.908.8726) / International: +1 214.379.6000
 Fax: +1 214.379.6073 / turbochef.com



COOKING OR HOT FOOD
STORAGE EQUIPMENT
ANSI/NSF#4 81Y5

Commercial Cooking Appliance with Integral Systems for Limiting the Emissions of Grease Laden Air

This product conforms to the ventilation recommendations set forth by NFPA96 using EPA202 test method.

Aparato de Cocina Comercial con Sistemas Integrales para Limitar las Emisiones de Aire cargado de Grasa

Este producto se conforma a la serie de recomendaciones de ventilación expuestas por NFPA96 Utilizando el Método de Prueba EPA202.

Appareil de cuisson commercial avec des systèmes qui limitent l'évacuation des vapeurs grasses

Ce produit est conforme aux recommandations de ventilation spécifiée par la norme. NFPA96, testé à l'aide de la méthode EPA202.

U.S. PATENTS PENDING

COVERED BY ONE OR MORE OF THE FOLLOWING U.S. PATENTS

5,254,823	5,434,390	5,558,793	5,620,731	5,927,265	5,990,466	6,008,483	6,058,924	6,060,701
6,140,626	6,262,406	6,359,271	6,376,817	7,087,872	7,092,988	7,493,362	8,224,892	

COVERED BY MEXICAN PATENT NO. 227157

KNGT.E319600 - COMMERCIAL COOKING APPLIANCES

Commercial Cooking Appliances

See General Information for Commercial Cooking Appliances

TURBOCHEF TECHNOLOGIES INC

E319600

2801 Trade Center Drive
Carrollton, TX 75007 USA

Ovens, Model(s) "*Fire*", *FIRE-AU*, *HHD*, *HHS*

Some models may also have Food Service Equipment, Sanitation Certification.

Last Updated on 2018-03-29

The appearance of a company's name or product in this database does not in itself assure that products so identified have been manufactured under UL's Follow-Up Service. Only those products bearing the UL Mark should be considered to be Certified and covered under UL's Follow-Up Service. Always look for the Mark on the product.

UL permits the reproduction of the material contained in the Online Certification Directory subject to the following conditions: 1. The Guide Information, Assemblies, Constructions, Designs, Systems, and/or Certifications (files) must be presented in their entirety and in a non-misleading manner, without any manipulation of the data (or drawings). 2. The statement "Reprinted from the Online Certifications Directory with permission from UL" must appear adjacent to the extracted material. In addition, the reprinted material must include a copyright notice in the following format: "© 2018 UL LLC".

UL and the UL logo are trademarks of UL LLC ©2018 All Rights Reserved.

[About](#) [Privacy Policy](#) [Terms & Conditions](#) [Access Your Data](#)

KNLZ.GuideInfo - COMMERCIAL COOKING APPLIANCES WITH INTEGRAL SYSTEMS FOR LIMITING THE EMISSION OF GREASE-LADEN AIR

[Heaters and Heating Equipment] (Heaters, Cooking Appliances) Commercial Cooking Appliances with Integral Systems for Limiting the Emission of Grease-laden Air

See General Information for Heaters, Cooking Appliances

USE AND INSTALLATION

This category covers cooking equipment intended for commercial use, such as pressurized deep fat fryers and other appliances for use in commercial kitchens, restaurants or other business establishments where food is prepared. Each appliance covered under this category is manufactured with an integral system feature to limit the emission of grease-laden air from the cooking process to the room ambient.

These appliances have been investigated for the limit of 5 mg/m³ for the emission of grease-laden air to the room ambient in accordance with the recommendations of ANSI/NFPA 96, "Ventilation Control and Fire Protection of Commercial Cooking Operations," using the EPA-202 test method prescribed for cooking appliances provided with integral recirculating air systems.

These products are not intended for connection to a ducted exhaust system.

Appliances in this category are not provided with an integral fire extinguishing system. Authorities having jurisdiction should be consulted as to the requirements for this equipment with respect to fire extinguishing systems, such as the need for field installed systems in accordance with ANSI/NFPA 96.

In cases where the nature or construction of equipment is such that special precautions beyond the requirements of ANSI/NFPA 70, "National Electrical Code," must be observed in installations or use, suitable warning or special instructions are marked on the equipment.

Appliances covered under this category are suitable for wiring with either copper or aluminum power-supply conductors unless marked "Use Copper Wire Only For Power Supply Connections."

Commercial cooking appliances of certain types are designed for permanent connections to water supply and sewer lines at the point of installation. Authorities having jurisdiction should be consulted as to the requirements for this equipment with respect to sanitation and connection to water supply and waste disposal lines.

FACTORS NOT INVESTIGATED

Neither the toxicity of coatings nor the physiological effects on persons consuming food products prepared by use of these appliances has been investigated.

PRODUCT IDENTITY

One of the following product identities appears on the product:

Commercial Cooking Appliance with Integral System for Limiting the Emission of Grease-laden Air

Cooking Appliance with Integral System for Limiting the Emission of Grease-laden Air

Other product identities may be used as shown in the individual certifications, followed by the words "with Integral System for Limiting the Emission of Grease-laden Air."

RELATED PRODUCTS

For products with integral recirculating systems including fire extinguishing systems, see Commercial, with Integral Recirculating Systems (KNKG).

For cooking oil filters that are not an integral part of another appliance, see Commercial Filters for Cooking Oil (KNRF).

ADDITIONAL INFORMATION

For additional information, see Electrical Equipment for Use in Ordinary Locations (AALZ) and Heating, Cooling, Ventilating and Cooking Equipment (AAHC).

REQUIREMENTS

The basic standard used to investigate products in this category is ANSI/UL 197, "Commercial Electric Cooking Appliances."

Appliances covered under this category with an integral cooking oil filter have been additionally investigated to ANSI/UL 1889, "Commercial Filters for Cooking Oil."

UL MARK

The Certification Mark of UL on the product is the only method provided by UL to identify products manufactured under its Certification and Follow-Up Service. The Certification Mark for these products includes the UL symbol, the words "CERTIFIED" and "SAFETY," the geographic identifier(s), and a file number.

Alternate UL Mark

The Listing Mark of UL on the product is the only method provided by UL to identify products manufactured under its Listing and Follow-Up Service. The Listing Mark for these products includes the UL symbol (as illustrated in the Introduction of this Directory) together with the word "LISTED," a control number, and the product name "Commercial Cooking Appliance" or "Cooking Appliance," or other appropriate product name as shown in the individual Listings, together with the words "with integral system for limiting the emission of grease-laden air."

* * * * *

UL, in performing its functions in accordance with its objectives, does not assume or undertake to discharge any responsibility of the manufacturer or any other party. UL shall not incur any obligation or liability for any loss, expense or damages, including incidental or consequential damages, arising out of or in connection with the use, interpretation of, or reliance upon this Guide Information.

Last Updated on 2013-05-16

The appearance of a company's name or product in this database does not in itself assure that products so identified have been manufactured under UL's Follow-Up Service. Only those products bearing the UL Mark should be considered to be Certified and covered under UL's Follow-Up Service. Always look for the Mark on the product.

UL permits the reproduction of the material contained in the Online Certification Directory subject to the following conditions: 1. The Guide Information, Assemblies, Constructions, Designs, Systems, and/or Certifications (files) must be presented in their entirety and in a non-misleading manner, without any manipulation of the data (or drawings). 2. The statement "Reprinted from the Online Certifications Directory with permission from UL" must appear adjacent to the extracted material. In addition, the reprinted material must include a copyright notice in the following format: "© 2018 UL LLC".

UL and the UL logo are trademarks of UL LLC ©2018 All Rights Reserved.
[About](#) [Privacy Policy](#) [Terms & Conditions](#) [Access Your Data](#)



**NOTICE OF COMPLETION
AND
AUTHORIZATION TO APPLY THE UL MARK**

08/11/2014

Turbochef Technologies Inc
Mr. DAVID CASTILLO
Suite 110
2801 Trade Center
Carrollton TX 75007

Our Reference: File E151487, Vol. 2 Project Number 4786393525
Your Reference: David Castillo – 22 April 2014
Project Scope: KNGT, UL 197 - E151487 V2 New Sec: USL-CNL, Commercial Pizza Oven, Model "Fire"

Dear Mr. DAVID CASTILLO:

Congratulations! UL's investigation of your product(s) has been completed under the above Reference Number and the product was determined to comply with the applicable requirements. This letter temporarily supplements the UL Follow-Up Services Procedure and serves as authorization to apply the UL Mark at authorized factories under UL's Follow-Up Service Program. To provide your manufacturer(s) with the intended authorization to use the UL Mark, you must send a copy of this notice to each manufacturing location currently authorized under File E151487, Vol. 2.

Records in the Follow-Up Services Procedure covering the product are now being prepared and will be sent in the near future. Until then, this letter authorizes application of the UL Mark for 90 days from the date indicated above.

Additional requirements related to your responsibilities as the Applicant can be found in the document "Applicant responsibilities related to Early Authorizations" that can be found at the following web-site:
<http://www.ul.com/EAResponsibilities>

Any information and documentation provided to you involving UL Mark services are provided on behalf of UL LLC (UL) or any authorized licensee of UL.

We are excited you are now able to apply the UL Mark to your products and appreciate your business. Feel free to contact me or any of our Customer Service representatives if you have any questions.

Very truly yours,

Rick Rynkiewicz
847-664-2631
Senior Staff Engineer
Richard.P.Rynkiewicz@ul.com

Reviewed by:

William R. Carney
847/664-1088
Chief Engineer Director I
William.R.Carney@ul.com

NBK9D8D-63AA76



**NOTICE OF COMPLETION
AND
AUTHORIZATION TO APPLY THE UL MARK**

08/29/2014

Turbochef Technologies Inc
Mr. DAVID CASTILLO
Suite 110
2801 Trade Ctr
Carrollton Tx 75007, Us

Our Reference: File E151487, Vol. TO BE DETERMINED Project Number 4786393525
Your Reference: David Castillo - 22Apr2014
Project Scope: TSQT, Sanitation - - E151487 V1 new sec: USL-CNL, sanitation on new model oven

Dear Mr. DAVID CASTILLO:

Congratulations! UL's investigation of your product(s) has been completed under the above Reference Number and the product was determined to comply with the applicable requirements. This letter temporarily supplements the UL Follow-Up Services Procedure and serves as authorization to apply the UL Mark at authorized factories under UL's Follow-Up Service Program. To provide your manufacturer(s) with the intended authorization to use the UL Mark, you must send a copy of this notice to each manufacturing location currently authorized under File E151487, Vol. TO BE DETERMINED.

Records in the Follow-Up Services Procedure covering the product are now being prepared and will be sent in the near future. Until then, this letter authorizes application of the UL Mark for 90 days from the date indicated above.

Additional requirements related to your responsibilities as the Applicant can be found in the document "Applicant responsibilities related to Early Authorizations" that can be found at the following web-site:
<http://www.ul.com/EAResponsibilities>

Any information and documentation provided to you involving UL Mark services are provided on behalf of UL LLC (UL) or any authorized licensee of UL.

We are excited you are now able to apply the UL Mark to your products and appreciate your business. Feel free to contact me or any of our Customer Service representatives if you have any questions.

Very truly yours,

Brandon T. Gray
847-664-3766
Staff Engineer
Brandon.T.Gray@ul.com

Reviewed by:

William R. Carney
847/664-1088
Chief Engineer Director I
William.R.Carney@ul.com

NBK9D8D-2DEEAC



2014-06-10

Mr. David Castillo
Turbochef Technologies Inc
4240 International Pky
Carrollton, TX 75007
Suite 105

E-mail: David.Castillo@turbochef.com

Our Reference: File E151487, Project 4786393525.3
Your Reference: D Castillo 22APR2014
Subject: E151487 - COMPLEMENTARY LISTING FOR MODEL FIRE PIZZA OVEN

Mr. Castillo:

Per your request, project 4786393525.3 was opened for the evaluation of grease-laden vapors produced by the Model FIRE Pizza oven. The scope of the project was to test this model in accordance with EPA Method 202 test guidelines to demonstrate compliance with UL710B, the Standard for Recirculating Systems, Sec. 17 and NFPA96, the Standard for Ventilation Control and Fire Protection of Commercial Cooking Operations, paragraph 4.1.1.2 for Complimentary Listing under UL's KNLZ category. The test was conducted at our facility in Northbrook, IL on May 16th, 2014. This letter will report the results of the EPA202 test.

For the record, the test was conducted on the FIRE Pizza oven, cooking thawed 12 in. pepperoni pizzas (Tombstone, with 19 pepperonis per pizza) as specified in Appendix A. Please see the attached page (Appendix A) for the test method and results of the tests. The results are considered to comply with UL710B, Section 17 and NFPA96, paragraph 4.1.1.2 since the measured values were less than the 5 mg/m³ limit.

Due to the Safety evaluation (4786393525.1) not being completed, this letter will serve to report that all tests on the subject product have been completed with acceptable results. After the successful completion of the safety project 4786393525.1, a Service Request will be opened to add the Complementary Listing to the Model FIRE Pizza oven. All information generated will be retained for future use. This concludes all work associated with project 4786393525.3 and we are therefore closing this project. Our Accounting Department has been instructed to bill you for all charges incurred.

Should you have any questions or comments concerning the above, please feel free to contact the undersigned.

Any information and documentation involving UL Mark services are provided on behalf of UL LLC or any authorized licensee of UL.

Sincerely,

Bill Morler
Sr. Project Engineer
Tel: 847-664-1852
E-mail: William.Morler@ul.com

Reviewed by:

Fred Zaplatosch
Sr. Staff Engineer
E-mail: fred.zaplatosch@ul.com



APPENDIX: A

TEST FOR EVOLUTION OF SMOKE OR GREASE-LADEN AIR:

The Turbochef model Fire Pizza oven was tested using the method derived from EPA Method 202.

A 12 in. by 6 in. rectangular, 108 in. tall sheet metal stack was constructed on top of a sheet metal hood and mounted above the exhaust vent of the induction cooker. A sampling port was located approximately 80 in. downstream from the hood exhaust, at which point it was determined there was laminar flow. The hood exhaust was maintained at 500 CFM throughout the duration of testing. The sampler was assembled and an out of stack filter was used. A pre-leak check was conducted and determined to be < 0.02 ft/min. Sampling was done at 8 traverse points.

The oven with integral system was operated normally by cooking the following foods:

12 in. pepperoni pizza (Tombstone, with 19 pepperonis per pizza), each cooked for 1 minutes with 50 seconds between loads for 8 hours (total of 222 pizzas). Oven was set to maintain 725°F upper heat and 700°F Lower heat

Temp	Event #	% Time.	% Top Fan heat	% Bottom Fan heat	% Microwave Energy
N/A °F	1	110sec	725°F	700°F	N/A
	2				

During the cooking operation, it was noted whether or not visible effluents evolved from the air exhaust of the hood. Gauge, meter and temperature readings were taken and recorded every 10 min. After cooking, the condition of the duct was noted and a post-leak check was conducted and determined to be < 0.02 ft³/min.

After being allowed to cool, the sampling equipment was disassembled; the filter was removed, and placed into a sample container labeled No. 1. The liquid in impingers Nos. 1, 2, and 3 were volumetrically measured and transferred to sample container No. 3. The silica gel and impinger No. 4 was transferred to sample container No. 5. The nozzle, probe and impingers were rinsed three times with water and the rinse was added to container No. 3. These parts were also rinsed three times with acetone and transferred to container No. 4. All additional inter surfaces of the sampling terrain glassware were rinsed with methylene chloride three times; the rinse was transferred to container No. 6. A blank of acetone approximately equivalent to the amount used for rinses was aliquoted into container No. 2, the same was done for the distilled de-ionized water and methylene chloride except that these were aliquoted into their own individual containers labeled No. 7 and 8 respectively. All containers were properly labeled and sealed, then the liquid levels in all the containers were marked.

The analysis phase was done in accordance with EPA Method 202, using the out of stack filter.



RESULTS:

There was no visible smoke emitted from the exhaust of the hood during the normal cooking operation of the Model FIRE Pizza oven. There was no noticeable amount of smoke accumulated in the test room after 8 hours of continuous cooking.

The total amount of grease-laden effluents collected by the sampling equipment for the Model FIRE Pizza oven was found to be 0.48 mg/m³, which is less than 5 mg/m³ limit.

UL® (KNLZ) Emissions by Product

Ventless Requirement: <5.00 mg/m³

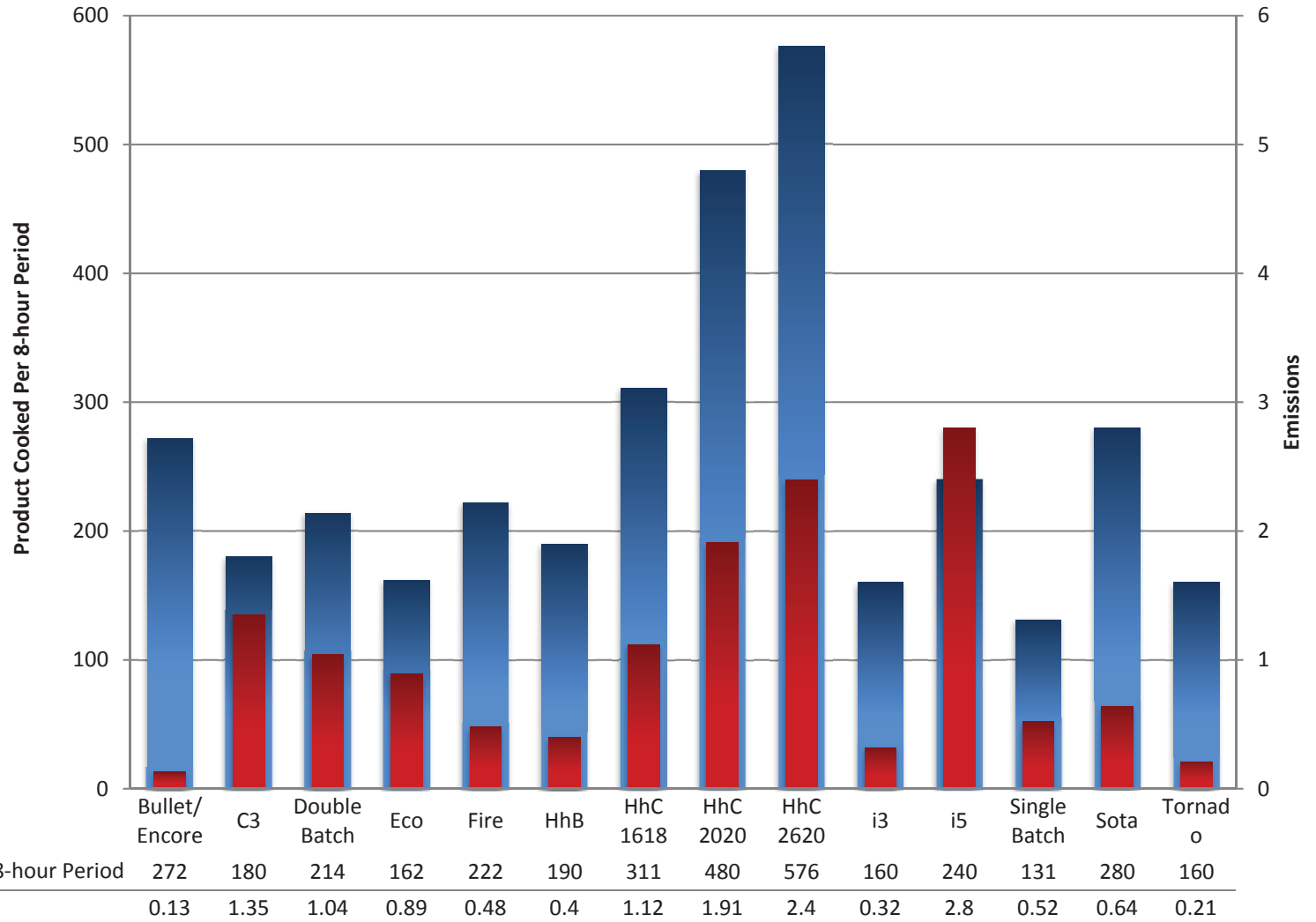

TurboChef Energy Calculator

User Inputs

Total Operation Time per Day (hours)	12	hours
Cook Cycle Time (seconds)	120	seconds
Number of Cooks per Day	50	total
Energy Cost/kWhr (\$)	0.11	\$/kWhr

Constants		Fire
Power Warm-up (watts)		3,500
Power Cooking (watts)		3,000
Power Idle (watts)		1,690
Time Warm-up (seconds)		600

Energy = (Power x time), where power is in watts and time is in seconds

$E_{total} = E_{idle} + E_{cooking} + E_{warmup}$

Ave Power = $E_{total} / \text{total time per day}$

Calculated Times		Fire
Time (cooking, sec)		6,000
Time (idle, sec)		36,600
Time Check		12
Eidle (kJ)		61,854
Ewarm-up (kJ)		2,100
Ecooking (kJ)		18,000
Etotal (kJ)		81,954
Etotal (kWhr)		22.77
Avg Power/Day (kW)		1.90
Tons of Cooling		0.54
Cost/Day (\$)		\$2.50
Cost/Month (\$)		\$75.00
Cost/Year (\$)		\$912.50

Fire Oven Surface Temperatures

This document illustrates the surface temperature testing data reported for the TurboChef Fire oven. Measurements were recorded after six hours of idle. The top oven temperature was set to 650°F/343°C and the bottom oven temperature was set to 750°F/399°C for the duration of the test.

After 6-hour Idle at 650°F (top) and 750°F (bottom)

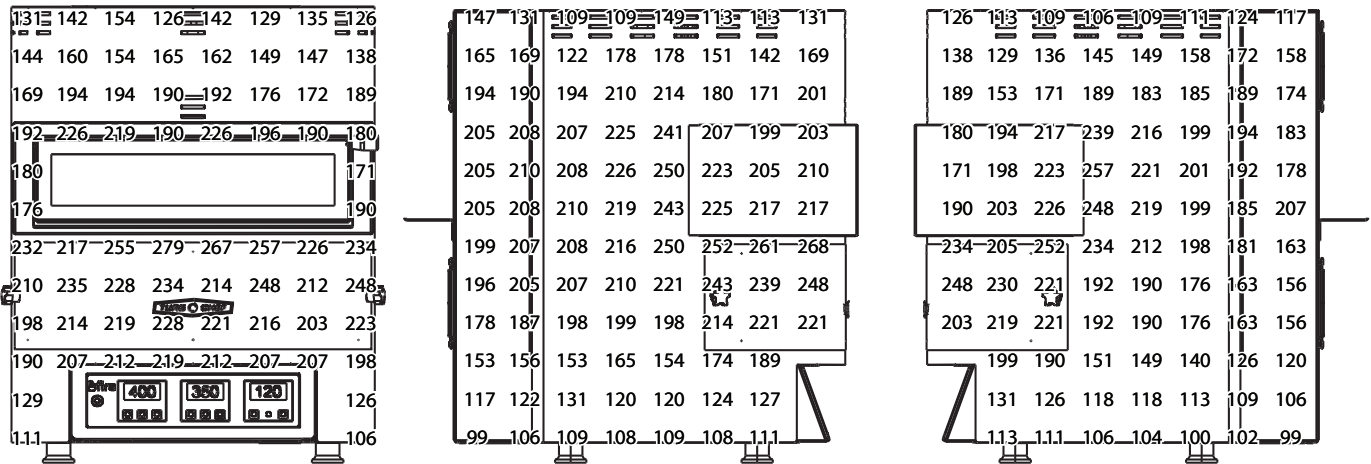

After 6-hour Idle at 343°C (top) and 399°C (bottom)

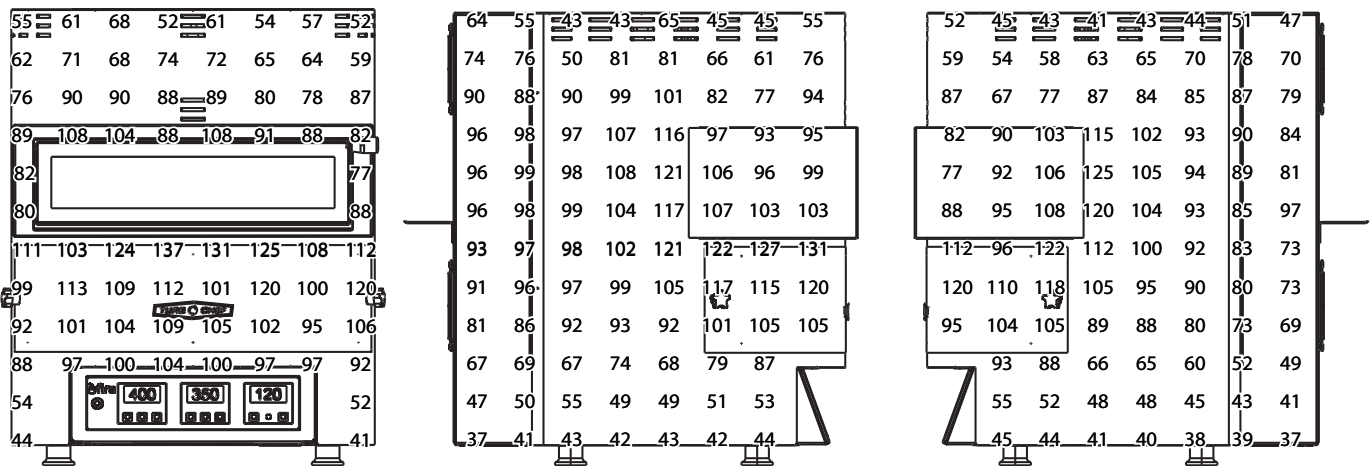



TURBOCHEF TECHNOLOGIES, INC.

Installation Recommendations

TurboChef ventless ovens have internal systems for destroying grease laden vapor prior to the grease escaping the oven; therefore, the ovens are certified as non-grease emitting appliances. When following our recommendations, TurboChef ovens can be installed without the aid of a Type I or Type II hood per International Mechanical Code (2006, 2009, and 2012), NFPA 96, NFPA 101 (Life Safety Code), EPA 202, and Underwriter's Laboratory (UL KNLZ).

The following guide is intended to give relevant information for the ventless installation, operation, and maintenance of TurboChef ovens. It is important that these guidelines are followed and that the oven and surrounding areas be maintained regularly for optimal performance.

Certifications

Safety – cULus, TUV (CE)

Sanitation – NSF*, UL EPH*

Ventless – UL (KNLZ)



Electrical Requirements

TurboChef ovens must be installed on a circuit equal to the ratings listed below, per NEC sec 210.23, permissible loads.

Oven	Voltage	Current	Phase
Bullet	208/240 VAC	30 amp	1 Ph
C3	208/240 VAC	50 amp	1 Ph
Double Batch	208/240 VAC	50 amp	1 Ph
	208/240 VAC	30 amp	3 Ph
Eco			
Encore/Encore 2	208/240 VAC	30 amp	1 Ph
Fire	208/240 VAC	30 amp	1 Ph
HhB 2	208/240 VAC	30 amp	1 Ph
HhC 1618	208/240 VAC	30 amp	3 Ph
	208/240 VAC	50 amp	1 Ph
HhC 2020	208/240 VAC	50 amp	3 Ph
HhC 2620	208/240 VAC	50 amp	3 Ph
i1 (Panini, Söta, Waterless Steamer)	208/240 VAC	30 amp	1 Ph
i1 Söta Single Mag	208/240 VAC	20 amp	1 Ph
i3	208/240 VAC	40 amp	1 Ph
	208/240 VAC	30 amp	3 Ph
i5	208/240 VAC	50 amp	1 Ph
	208/240 VAC	30 amp	3 Ph
Single Batch	208/240 VAC	30 amp	1 Ph
Tornado	208/240 VAC	30 amp	1 Ph

* NSF certification applies to the Tornado, C3, and HhB 2 ovens only. UL EPH certification applies to all ovens except the C3.

Menu Requirements

TurboChef ovens have been approved by Underwriter's Laboratory for ventless operation (UL KNLZ listing) for all food items EXCEPT for foods classified as "fatty raw proteins." Such foods include bone-in, skin-on chicken, raw hamburger meat, raw bacon, raw sausage, steaks, etc.

The TurboChef certification includes precooked food items such as pizza toppings, sandwich meats, frozen appetizers, and cheeses. Additionally, raw, lean meats such as boneless, skinless chicken breasts and fish fall within the certification.

Cleaning Requirements

To ensure continued compliance with all health, building, and fire codes, users are required to:

- Use only TurboChef-approved cleaning chemicals.
- Follow monthly and quarterly cleaning instructions provided in the manual. Post cleaning instructions near the oven.
- Ventless installation requires that the areas around the oven (walls, ceilings, kitchen equipment, etc.) be cleaned as needed but no less than once every other month.

Installation Near Open Heat Source

When placing a TurboChef oven near an open heat source (see illustration below), strictly adhere to the following:

- If the oven is being placed near a grill or stove, a divider must exist between the oven and the open heat source, with a minimum of 6" (152 mm) between the oven and the divider.
- If the oven is being placed near a fryer, a divider must exist between the oven and fryer, with a minimum of 12" (305 mm) between the oven and the divider.
- The height of the divider must be greater than or equal to the height of the oven.

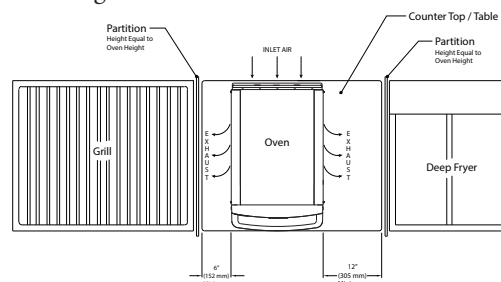



Oven Clearances

Verify the oven location has the following clearances on the top and each side. TurboChef ovens have built-in back bumpers that allow for the necessary spacing from the oven to the back wall.

Oven	Top	Sides
Bullet	5" (127 mm)	2" (51 mm)
C3	4" (102 mm)	2" (51 mm)
Double Batch	2" (51 mm)	2" (51 mm)
Eco	5" (127 mm)	1" (25 mm)
Encore/Encore 2	5" (127 mm)	2" (51 mm)
Fire	2" (51 mm)	2" (51 mm)
HhB 2	2" (51 mm)	2" (51 mm)
HhC 1618	10" (254 mm)	0" (0 mm)
HhC 2020	10" (254 mm)	0" (0 mm)
HhC 2620	10" (254 mm)	0" (0 mm)
i1 (Panini, Söta / Söta Single Mag, Waterless Steamer)	5" (127 mm)	1" (25 mm)
i3	19" (483 mm)	2" (51 mm)
i5	19" (483 mm)	2" (51 mm)
Single Batch	2" (51 mm)	2" (51 mm)
Tornado	4" (102 mm)	2" (51 mm)

Ventilation

TurboChef ovens must be installed in a well-ventilated space. The space should have an exhaust rate of .70 cfm per square foot of kitchen space and an additional 100 sq. ft. (9.3 m²) of virtual space per ventless cooking appliance (TurboChef or any other).

If the air inlet is for general exhaust, pursuant to requirements for 507.2.2, paragraph 2, locate the air inlet above the center point of each oven.

The heat load from TurboChef ovens is mostly sensible. The only latent heat present is due to evaporation during the cooking process. When installing a TurboChef oven, the space must have the following tons of AC per oven installed.

Oven	Tons of AC
Bullet	0.5
C3	0.63
Double Batch	1.15
Eco	0.89
Encore/Encore 2	0.45
Fire	0.55
HhB 2	0.84
HhC 1618	1.00
HhC 2020	1.47
HhC 2620	1.82
i1 (Panini, Söta/ Söta Single Mag, Waterless Steamer)	0.3
i3	0.9
i5	1.3
Single Batch	0.75
Tornado	0.58

How the Ovens are Tested

TurboChef ovens are evaluated according to UL. The evaluation entails placing the test oven in an environmental chamber built to capture all emissions escaping during idle, cooking, and door-open conditions. During the eight-hour test period, a typical worst-case food item is cooked continuously, and 100% of condensable and non-condensable emissions from the product are collected and analyzed according to the EPA 202 Test Method. At the conclusion of the test, the total concentration of particulate matter (emissions) must be less than 5.0 mg/m³ for the oven to be certified for ventless operation. Cooking devices that measure above the 5.0 mg/m³ threshold are considered to produce grease and must be installed under Type I ventilation, according to International Mechanical Code.

TurboChef ovens are well below the 5.0 mg/m³ threshold as shown below.

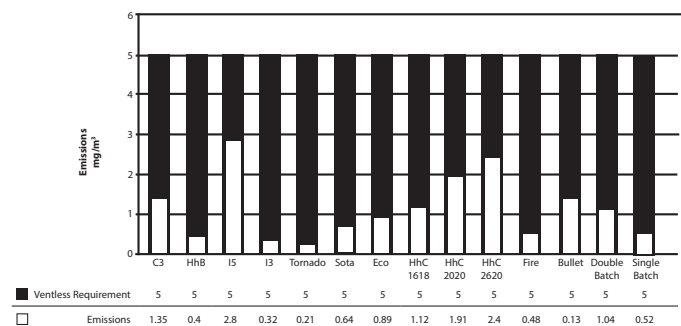

Contact Information

For questions regarding a ventless installation, email ventless.help@turbochef.com. For questions or concerns regarding an existing installation, contact Customer Service at 1.800.908.8726, Option 1.



CYNTHIA A. HARDING, M.P.H.
Interim Director

JEFFREY D. GUNZENHAUSER, M.D., M.P.H.
Interim Health Officer

ANGELO J. BELLOMO, REHS, QEP
Director of Environmental Health

TERRI S. WILLIAMS, REHS
Assistant Director of Environmental Health

Brenda J. Lopez, REHS
Director, Bureau of Specialized Surveillance and Enforcement

5050 Commerce Drive
Baldwin Park, California 91706
TEL (626) 430-5100 • FAX (626) 813-3000

www.publichealth.lacounty.gov

BOARD OF SUPERVISORS

- Hilda L. Solis
First District
- Mark Ridley-Thomas
Second District
- Sheila Kuehl
Third District
- Don Knabe
Fourth District
- Michael D. Antonovich
Fifth District

April 17, 2015

David Castillo
VP of Engineering
Giga and TurboChef Technologies, Inc.
2801 Trade Center
Carrollton, TX 75007

Ventilation Exemption Plan Check No.	ME-2015-002
Application Type:	Equipment specific – Model – Fire-208/240 V, 3700/4800 watts
Effective Date:	4-17-2015
Expiration Date:	4-17-2020
Telephone:	(214) 379-6023
Email:	david.castillo@turbochef.com

Dear Mr. Castillo:

RE: EXEMPTION FROM MECHANICAL EXHAUST VENTILATION FOR TURBOCHEF ELECTRIC OVEN MODEL FIRE

The County of Los Angeles Department of Public Health, Environmental Health, Plan Check Program, has completed a review of the TurboChef Fire oven for exemption from the mechanical exhaust ventilation requirements of Section 114149.1(a) of the California Retail Food Code.

You have provided documentation that this oven has Underwriter’s Laboratory UL certification for safety and sanitation, and also provided the UL results of the eight-hour cooking emissions test conducted on the model Fire.

TurboChef Fire
April 17, 2015
Page 2 of 3

The test results indicate that the total amount of grease-laden effluents collected was 0.48 mg/m³, which is below the limit of 5 mg/ m³ to be considered a low grease emission appliance.

Therefore, additional mechanical ventilation in the form of a Type I or Type II hood is not required by the County of Los Angeles Department of Public Health, provided the following contingencies are met:

1. There shall be no more than two unventilated TurboChef Fire ovens per food facility. If the ovens are double stacked, then this is considered two ovens.
2. No other heat producing food related equipment requiring ventilation shall be permitted in a food facility without the addition of mechanical ventilation.
3. The equipment must be installed, serviced, and maintained according to the manufacturer's specifications.
4. Any modification or alteration of the equipment, including any component of the integral air filtration system voids both the ANSI certification of the equipment and this limited exemption.
5. The TurboChef Fire oven shall be used for the cooking or warming of pizza, bread, bakery products, sandwiches containing ready to eat fillings, or similar items only. No raw animal protein products shall be cooked in the equipment unless mechanical ventilation is provided.
6. No items that generate grease-laden vapors shall be prepared or cooked in the unventilated TurboChef Fire oven. Pre-cooked foods such as animal, fish or skinless poultry protein products may be reheated in the TurboChef Fire.
7. The TurboChef Fire oven(s) must be operated in a well-ventilated area approved for food preparation.
8. If a food facility that is operating this exempt equipment changes ownership, then the new owner/ operator shall comply under the same operating conditions.
9. This exemption from mechanical exhaust ventilation shall not be deemed to supersede any local building and fire code requirements pertaining to mechanical, electrical and/or fire safety.

This exemption shall be in effect for a period of five years from the date of this letter, or until revoked. Further, this exemption shall not preclude this Department from requiring the installation of mechanical exhaust ventilation when operation of the TurboChef Fire oven(s) at a specific location results in a sanitation or safety violation.

TurboChef Fire
April 17, 2015
Page 3 of 3

This letter may be used as evidence of the evaluation of the TurboChef Fire oven. However, it is not to be construed as an endorsement of the subject items and may not be used for advertising or promotional services.

If you have any questions, please contact the Plan Check Program at (626) 430-5560.

Sincerely,



Swati Bhatt, M. S., R.E.H.S.
Chief Environmental Health Specialist
Plan Check Program
5050 Commerce Drive
Baldwin Park, CA 91706