

VM 14/90n



Strong



Compact dimensions



Rapid vacuum

Patented for packaging products in smooth bags

Ideal for the packaging of medium-large sized products, VM 14/90n stands out thanks to a 520 mm sealing bar and the innovative retractable probe: a special system patented by Orved that allows the maximum suction of air using a smooth vacuum bag, ensuring a vacuum level of absolute excellence. This innovative system allows the VM 14/90n to be versatile, packaging any solid product in both smooth and embossed bags. VM 14/90n is also equipped with a special polyethylene shelf that allows the packaging machine to facilitate the support of the bag during the packaging cycle.

VM 14/90n is ideal for:



Domestic kitchens



Bar



Grocery stores

Packing methods



Sealing only



Vacuum

Technical data

- > Bodywork: stainless steel
- > Size: 565x480x280h mm
- > Vacuum pump: 4 mc/h oil-lubricated
- > Sealing bars: 520 mm
- > Weight: 37 kg
- > Max power absorption: 1350 W
- > Power grid voltage: 230V 50/60Hz

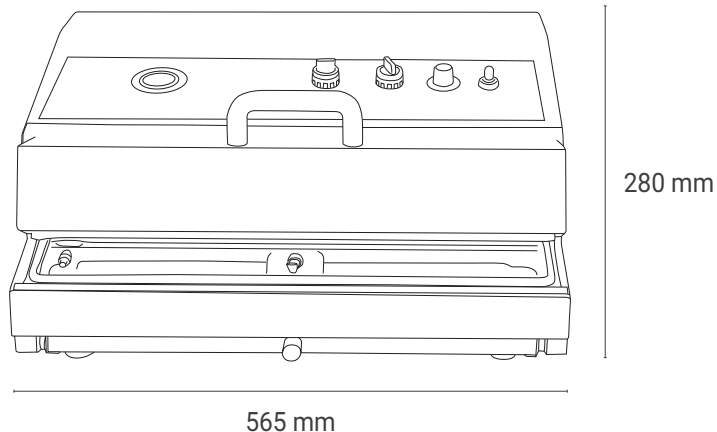

Standard equipment



Device to operate vacuum in container



Automatic + Manual system

Optionals on request



Suction tube

Matching accessories



Channelled vacuum bags



Conserbox containers