

ISM-1800 Heavy Duty Commercial Microwave



1800W of Power

Shorter cook times and speed of service.

17.9L

Large 17.9L Capacity

Serves a high volume of food in a shorter space of time. Accommodates a 12" (305mm) platter.

100

100 Auto Programs

Deliver consistent results and reduce under and overcooking. Bulk menu changes by USB.



3 Year Warranty

On-site parts and labour warranty, backed by Marren employed nationwide engineers.

Microwave Specifications and Features:

Marren ISM-1800 Heavy Duty Commercial Microwave comprises a user-friendly touch pad, programmable with up to 100 auto settings and 00:60:00 minutes of maximum cook time for each program. Includes a USB feature for consistent menu optimisation and fitted with an interior LED light to help monitor food items, without the need to open the door. The oven has 11 power levels and 3 cooking stages, featuring a time entry option and X2, X3 multiple quantity touch pad. Manufactured with 1800W of power, distributed by dual magnetrons and delivered by top and bottom rotating antenna for even cooking and speed of use. The large 0.63 cubic ft. (17.9L) cavity is perfect for food outlets with high volume food demands and comes with stainless steel durable door and EZ Grab and Go handle with 90°+ opening for easy access. Manufactured with stainless steel exterior wrap, door, interior cavity, removable roof liner and stainless steel air intake filter for easy cleaning. Designed to be stacked with the same style oven to help reduce footprint. Requires a 230v power supply and supplied with a 13a plug for ease of installation. Cavity liner available as an optional extra.



Marren ISM-1800 1800W

Specifications and Features

- Large capacity (0.63 cu.ft/17.9L), accommodates a 12" (305 mm) platter
- Able to withstand the demands of the Commercial Foodservice environment with a stainless steel cabinet and oven cavity
- 1800 Watts of Cooking power
- Top and Bottom Energy Feed
- 11 power levels and 3 cooking stages for different cooking demands
- 00:60:00 maximum cooking time and 100 auto programs can cover most product demands
- User-friendly touch control pad, great for self-service locations and speed of use
- Time entry option and X2, X3 multiple quantity pad provided for flexible operation
- USB port for efficient and consistent menu optimisation used for multiple locations
- Removable Roof liner and stainless steel air intake filter for easy cleaning
- Oven cavity LED light to monitor food items and cooking status without opening the door
- EZ Grab'n Go door handle for reliable use, no moving parts
- Stackable in sets of two, which helps to reduce footprint
- 230V operation, (13 Amp) plug supplied
- Cavity liner available as an optional extra
- 3 Year Manufacturer on-site parts and labour warranty backed by Marren employed Nationwide engineers

FRONT VIEW

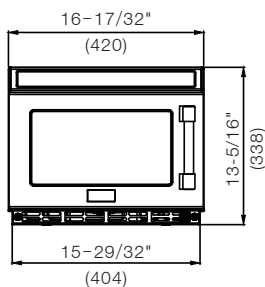

SIDE VIEW (DOOR OPEN)

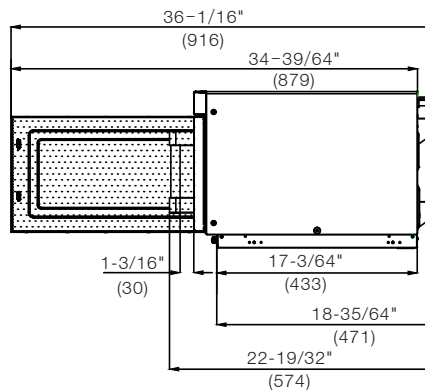

BACK VIEW

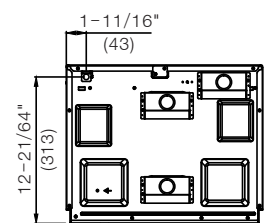

ISM-1800 Specifications

| | | | |
|-----------------|------------------|------------------------|-------------------|
| Cavity Size | 0.63 cu.ft/17.9L | Auto Programmable | 100 - USB feature |
| Max Power Input | 3000 Watts | Power Levels | 11 |
| Power Output | 1800 Watts | Stage Cooking | 3 |
| Power Source | 230V/50Hz | Max Cooking Time | 00:60:00 |
| Exterior Finish | Stainless Steel | Multiple Portion | Yes |
| Interior Finish | Stainless Steel | Magnetrons | 2 |
| Control Type | Membrane Touch | Microwave Distribution | Top and bottom |
| Interior Light | LED | Stackable | Yes, 2 |
| Turntable | No | Safety Listing | CE/EMC/GS/CB |

Measurements

Cavity (WxDxH)

330mm x 310mm x 175mm

Gross (WxDxH)

420mm x 563mm x 340mm

Package (WxDxH)

640mm x 507mm x 416mm

Product Weight (approx)

30KG

Ship Weight (approx)

32KG