

# Start Strong with Basics Plus



- Lifetime warranty against rust and corrosion.
- Easy to clean and adjust.
- Shared post design creates extra storage space.
- Simple to assemble straight from the box.

**CAMBRO**  
TRUSTED FOR GENERATIONS™

# The New CAMSHELVING® **BASICS PLUS** series

Strong yet cost-efficient, Basics Plus Series can handle the demands of any foodservice operation. Minimize total cost without sacrificing quality or stability with new Basics Plus Series.

Available in:

HEIGHTS	DEPTHS		LENGTHS	
<b>3</b>	<b>3</b>		<b>6</b>	
1630 mm	460 mm	610 mm	765 mm	1220 mm
1830	540		915	1375
2140			1071	1525

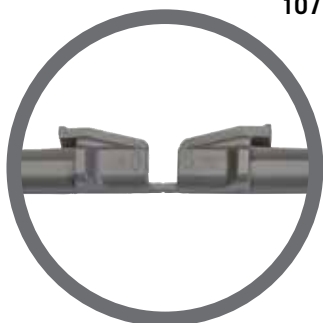

**Breakaway dovetail design speeds up and organizes installation.**



**Large traverse end piece wraps securely onto post for maximum stability.**

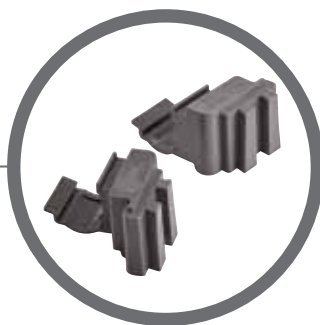

**Corner connectors maximize storage space and provide easy access to shelf contents.**







**Shelf plates are easy to remove and run through the dishwasher.**



**Hefty dovetails keep shelves securely in place.**



**Traverses are able to share the middle post to maximize space.**



**Choose solid or vented shelves for many applications.**

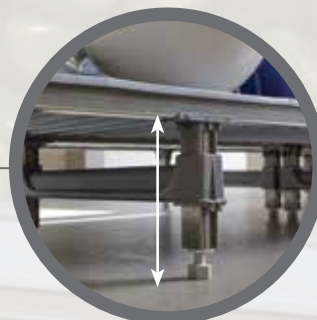

**Use dunnage stands for added support.**



# Complete Foodservice Solutions

Cambro is proud to offer our Camshelving Design Service (CDS), which creates a custom shelving plan for you that maximizes space and creates an efficient operational flow. With some simple information, our expert shelving consultants will prepare 2D and 3D floor plans so you can see how your new shelving will look and function.



## It's Simple to Get Started!

Visit [www.cambro.com/camshelving](http://www.cambro.com/camshelving) for more information.

## Weight Bearing Capacity

Weight must be evenly distributed across the entire shelf.

		UNIT LENGTH 765 – 1220 MM	UNIT LENGTH 1375 – 1525 MM
<b>SINGLE UNIT</b>	Unit only	800 kg (TUV)	800 kg (TUV)
	Shelf only	190 (TUV)	180 (TUV)
	Unit with dunnage stand*	885	880
	Bottom shelf with dunnage stand*	275	260
<b>CORNER UNIT</b> with 2 dunnage stands required	Unit only	590	—
	Shelf only	130	—
	Bottom shelf with dunnage stands*	200	—

\* Dunnage Stands add stability and increase weight bearing capacity on bottom shelf only. Highly recommended for Starter Units 1375 mm and longer, all Corner Units, U-Shape Units and units specified for heavier loads.

 TUV CERTIFICATION  
WEIGHT BEARING CAPACITY



COMPONENT

Post Connectors, Corner Connectors, Seismic Foot, Wall Fastener, and Identification Tags are not NSF listed.

Product specifications are subject to change without prior notification.

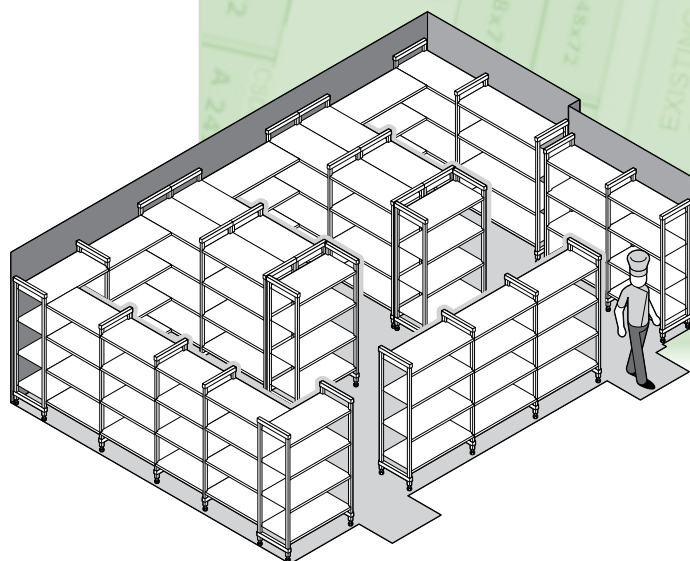
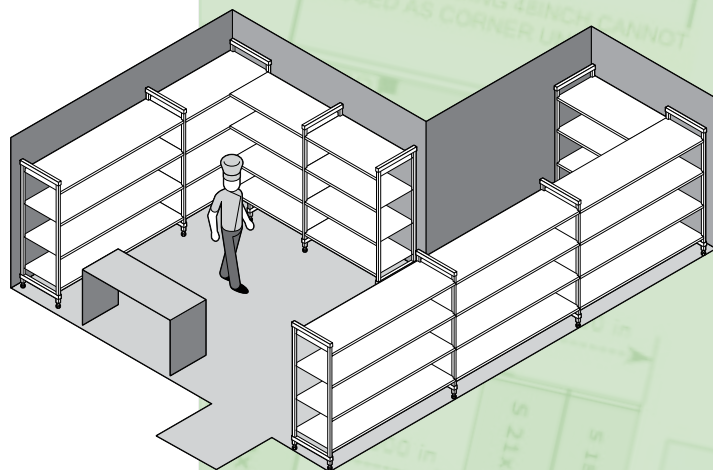

## Optional Accessories

- Corner Connector Sets
- Bottom Shelf Dunnage Stands (Low or Tall)
- Shelf Identification Tags
- Wall Fastener
- Seismic Foot
- Shelf Divider Panel
- Single Shelf Sheet Pan/Tray Rack
- Single Shelf Security Cage
- Shelf Traverses
- Drying and Storage Cradles (610 mm Deep Only)

**CAMBRO**  
TRUSTED FOR GENERATIONS™

CAMBRO U.S.A.  
TEL: 1(714) 848-1555  
FAX: 1(714) 230-4375  
international@cambro.com

CAMBRO EUROPEAN LOGISTICS  
TEL: (49) 7022 90 100 0  
FAX: (49) 7022 90 100 19  
cambroeuropa@cambro.com

CAMBRO UK  
TEL: 0800 587 0057 Toll Free  
FAX: 0845 280 3411  
cambrouk@cambro.com

CAMBRO IRELAND  
TEL: 1800 509 046 Toll Free  
FAX: 01 633 55 76  
cambroireland@cambro.com

© Copyright Cambro Manufacturing Company. Printed in the U.S.A.

LITX17BPSSN

108775